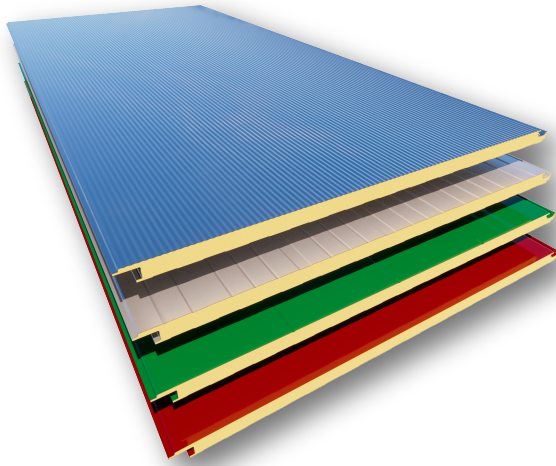

FAÇADE PANEL MPF/PRF/SML/LIS
FAÇADE PANEL

EXTERIOR FACE
 Pre-painted steel

INSULATION
 Polyurethane (PUR) and
 Polyisocyanurate (PIR)

INTERIOR FACE
 Pre-painted steel

THICKNESSES mm (in.)
35/40/50/60/80/100
 (1.38/1.57/1.97/2.36/3.15/3.94)

USEFUL WIDTH
 1100 mm (43.31 in.)

USE
 Façades

TECHNICAL SPECIFICATIONS

Panel for façade cladding comprised of 2 steel sheets and a polyurethane (PUR) or polyisocyanurate (PIR) insulating foam core on the inside which guarantees maximum thermal insulation. It can be installed both vertically and horizontally. In both cases, the connection between the panels is by means of a tongue-and-groove joint with a screwing system with hidden fastening.

Its surface finish can be smooth, semi-smooth, ribbed or micro-profiled.

MAIN CHARACTERISTICS OF THE 35 mm [1.38 in.] PANEL

Nominal thickness	35 mm (1.38 in.) (±3 mm/0.12 in.)
Average foam density	40 kg/m ³ (±10%)
Weight	10.80 kg/m ²
Volume	35 m ² /m ³
Useful width	1100 mm (43.31 in.) (±3 mm/0.12 in.)
Straightness	0 mm (±5 mm/0.20 in.)
Contraction - Inflection lengthwise	0 mm (±5 mm/0.20 in.)
Compressive strength	0.096 MPa
Tensile strength	0.092 MPa
Fire resistance PUR-UNE 13501-1	until B-s2-d0 *
Fire resistance PIR-UNE 13501-1	until B-s1-d0 *
Behavior against fire on the exterior	Broof (t1) for sheet thickness →0.4 mm

(* consult regarding other classifications)

THERMAL INSULATION AND WEIGHT

TRIBBED PANEL	HEAT TRANSFER		WEIGHT(0.5/0.5)
Nominal thickness in mm (in.)	K in Kcal/ m ² .h. °C	K in W/m ² .k	Kg/m ²
35 (1.38)	0.50	0.59	10.80
40 (1.57)	0.44	0.52	11.00
50 (1.97)	0.36	0.43	11.40
60 (2.36)	0.30	0.36	11.80
80 (3.15)	0.23	0.27	12.60
100 (3.94)	0.18	0.21	13.40

The weight includes the proportional part of the accessory elements.

ACOUSTIC INSULATION
EXPERIMENTAL VALUES FOR THE 35 mm PANEL

Frequency Hz	125	250	500	1000	2000	4000
Acoustic insulation db	25	27.5	29	28.5	31	37.5

Standard panel of 35 mm thickness. Mean (TL) 28.8 db

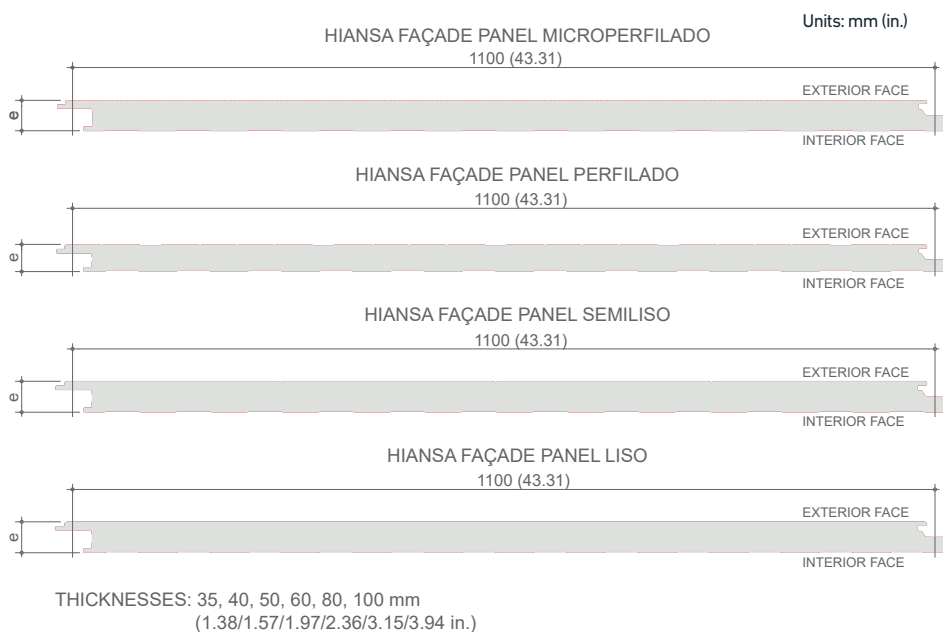
GEOMETRIC SPECIFICATIONS

Units: mm (in.)

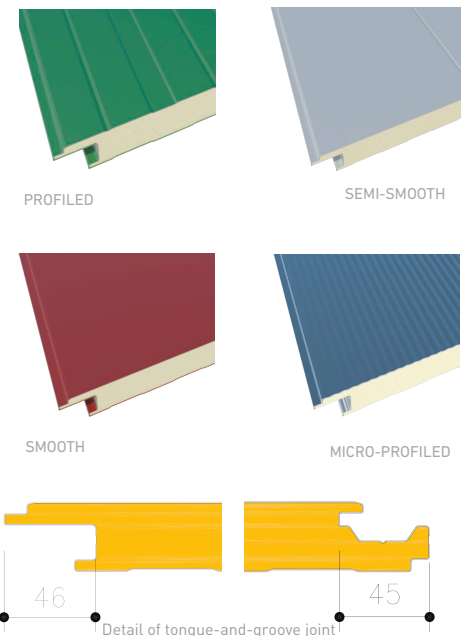

STANDARDS APPLIED

Ref. Standard	Description
EN 14509-2014	Metal double-sided insulated self-supporting sandwich panel. Products made at the factory. Specifications.
EN 13823	Reaction to fire tests of construction products. Construction products, excluding floor coverings exposed to thermal attack caused by a single burning object.
EN 10169	Flat steel products, continuous coated with organic materials (pre-painted). Technical supply conditions.
EN 13501	Classification based on the fire performance of construction products and building elements. Part 1.

CONSTRUCTION DETAILS

The panel can be mounted both vertically and horizontally by means of the tongue-and-groove joint, ensuring in both cases the continuity of the exterior wall, which guarantees optimal thermal and acoustic performance.

HORIZONTAL MOUNTING

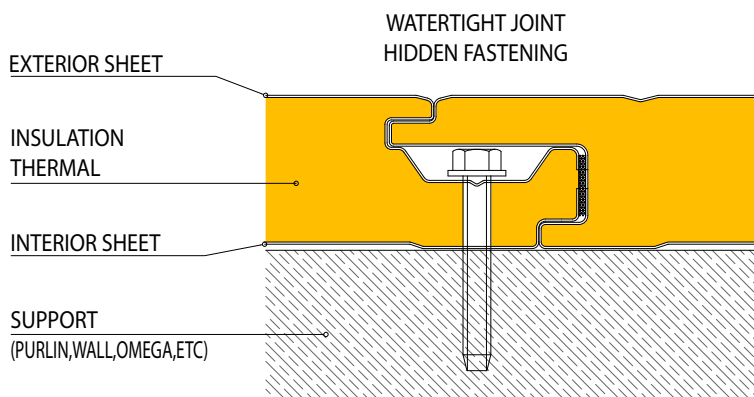

VERTICAL MOUNTING

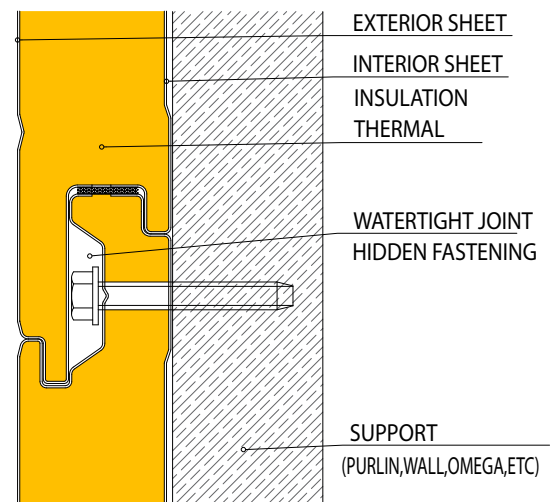

DETAIL OMEGA VERTICAL JOINT

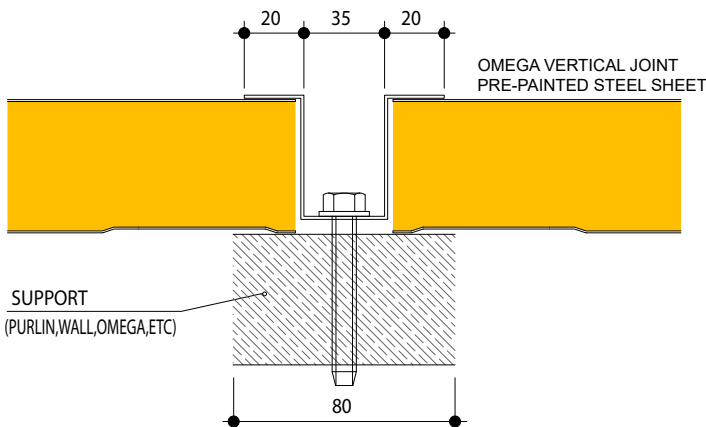

RESISTANCE TABLES

FAÇADE PANEL													
MAXIMUM PRESSURE AND SUCTION LOAD VALUES (m/n) in kp/m ²													
Panel thickness (mm)	d	35				40				50			
Thickness of faces (mm)	e1/e2	0.4/0.4	0.5/0.4	0.5/0.5	0.6/0.5	0.4/0.4	0.5/0.4	0.5/0.5	0.6/0.5	0.4/0.4	0.5/0.4	0.5/0.5	0.6/0.5
SPAN (L) FOR 1 OPENING	1.5	307/307	317/317	327/327	333/333	375/375	385/385	396/396	404/404	515/515	528/528	541/541	550/550
	2.0	176/176	184/184	193/193	199/199	220/220	229/229	239/239	246/246	312/312	324/324	337/337	345/345
	2.5	108/108	114/114	121/121	126/126	137/137	144/144	153/153	159/159	200/200	210/210	221/221	229/229
	3.0	69/69	74/74	79/79	83/83	89/89	95/95	102/102	106/106	133/133	142/142	151/151	158/158
	3.5	46/46	50/50	54/54	57/57	60/60	65/65	70/70	74/74	92/92	99/99	106/106	112/112
	4.0	32/32	34/34	38/38	40/40	42/42	45/45	49/49	52/52	66/66	71/71	77/77	81/81
SPAN (L) FOR 2 OPENINGS	1.5	246/357	241/362	234/366	229/369	240/426	234/432	227/437	222/441	228/570	221/576	214/581	209/581
	2.0	196/227	193/232	188/238	185/241	192/274	188/274	183/287	180/291	184/343	180/343	175/389	171/394
	2.5	153/117	142/153	157/163	155/167	160/146	157/175	154/200	151/204	154/212	151/219	148/277	145/280
	3.0	101/66	80/106	116/96	119/119	122/82	98/122	133/120	131/148	133/116	131/152	128/173	126/194
	3.5	67/42	50/78	85/60	76/88	80/51	61/89	107/74	93/110	108/72	86/112	113/105	111/143
	4.0	47/29	34/57	63/41	52/65	56/35	42/68	77/49	63/83	75/48	58/86	101/69	88/109
4.5	35/21	25/42	47/29	37/50	42/25	30/50	57/35	45/61	55/34	41/67	76/49	62/82	
Panel thickness (mm)	d	60				80				100			
Thickness of faces (mm)	e1/e2	0.4/0.4	0.5/0.4	0.5/0.5	0.6/0.5	0.4/0.4	0.5/0.4	0.5/0.5	0.6/0.5	0.4/0.4	0.5/0.4	0.5/0.5	0.6/0.5
SPAN (L) FOR 1 OPENING	1.5	587/661	587/676	587/690	587/698	587/934	587/934	587/933	587/933	587/934	587/934	587/933	587/933
	2.0	410/410	425/412	440/440	440/450	440/550	440/550	440/656	440/668	440/550	440/550	440/656	440/668
	2.5	264/264	282/264	295/295	305/305	352/352	352/352	352/450	352/449	352/352	352/352	352/450	352/449
	3.0	183/183	194/183	206/206	214/214	245/245	293/245	293/312	293/312	245/245	293/245	293/312	293/312
	3.5	129/129	137/134	147/147	154/154	180/180	225/180	229/229	249/229	180/180	225/180	229/229	249/229
	4.0	93/93	100/100	108/108	114/114	138/138	167/138	176/176	188/176	138/138	167/138	176/176	188/176
SPAN (L) FOR 2 OPENINGS	1.5	217/700	211/699	203/699	197/698	200/934	193/934	185/933	179/933	200/934	193/934	185/933	179/933
	2.0	177/412	173/412	167/495	163/500	165/550	160/550	154/700	150/700	165/550	160/550	154/700	150/700
	2.5	149/264	146/264	142/337	139/336	140/352	136/352	132/450	128/449	140/352	136/352	132/450	128/449
	3.0	129/157	126/183	123/234	121/234	122/245	119/245	115/312	113/312	122/245	119/245	115/312	113/312
	3.5	114/95	112/134	109/141	107/172	108/152	106/180	130/228	100/229	108/152	106/180	130/228	100/229
	4.0	97/63	76/103	98/92	96/131	97/99	95/138	93/146	91/176	97/99	95/138	93/146	91/176
4.5	70/45	53/81	89/64	81/104	88/69	83/109	84/100	83/139	88/69	83/109	84/100	83/139	

Permissible service loads, uniformly distributed in kg/m². The tables have been obtained based on a calculation methodology established in accordance with the provisions of the EAE-2012 standard and the EC-3, considering only the upper steel sheet as a structural element. These results comply with the Ultimate Limit States of normal and tangential stresses prescribed in said standards and with a limitation of the Serviceability Limit State for deformations of L/200.